

2. Guz', O. M., On a variational principle of three-dimensional elastic stability theory for large subcritical strains. *Dop. Akad. Nauk USSR, Ser. A*, № 3, 1971.
3. Babich, I. Iu. and Guz', O. M., Variational principle of dynamical linearized elasticity theory problems for incompressible bodies under highly-elastic strains. *Dop. Akad. Nauk USSR, Ser. A*, № 10, 1971.
4. Babich, I. Iu. and Guz', O. M., On variational principles of the Khu - Vashitsu type for linearized problems of highly-elastic deformations. *Prikl. Mekhan.*, Vol. 8, № 3, 1972.
5. Guz', A. N., Variational principles of linearized problems of elasticity theory for high initial strains. In: *Mechanics of a Continuous Medium and Kindred Analysis Problems*, "Nauka", Moscow, 1972.
6. Guz', A. N., Three-dimensional theory of elastic stability for finite subcritical strains. *Prikl. Mekhan.*, Vol. 8, № 12, 1972.
7. Guz', A. N., On the question of linearized problems of elasticity theory. *Prikl. Mekhan.*, Vol. 8, № 1, 1972.
8. Guz', A. N., *Stability of Elastic Bodies under Finite Strains*. "Naukova Dumka", Kiev, 1973.
9. Alfutov, N. A. and Balabukh, L. I., Energy criterion of the stability of elastic bodies which do not require the determination of the initial stress-strain state. *PMM Vol. 32*, № 4, 1968.
10. Bolotin, V. V., On variational principles of elastic stability. In: *Problems of the Mechanics of a Solid Deformed Body*. Sudostroenie, Leningrad, 1970.
11. Vujanovic, B., Synge's disturbed equations as a variational problem and their first integrals. *Bull. Acad. Roy. Belgique. Cl. Sci.*, Sér. 5, Vol. 51, № 6, 1965.
12. Djukić, D., A contribution to the analytical mechanics of the disturbed motion. *Bull. Acad. Roy. Belgique. Cl. Sci. Ser. 5*, Vol. 58, № 1, 1972.
13. Nemat-Nasser, S., On variational methods in finite and incremental elastic deformation problems with discontinuous fields. *Quart. Appl. Math.*, Vol. 30, № 2, 1972.

Translated by M. D. F.

UDC 539.3

SOLUTION OF A HOMOGENEOUS BOUNDARY VALUE PROBLEM FOR THE SECTOR OF A TOROIDAL SHELL SEGMENT

PMM Vol. 40, № 4, 1976, pp. 755-759

V. M. BOGOMOL'NYI and R. D. STEPANOV

(Moscow)

(Received March 17, 1975)

Membrane forces in the segment of a thin toroidal shell loaded by an edge bending load are determined from the particular solution of the fundamental differential equation. Taking account of the asymptotic approximation of the special function in whose terms the particular solution is expressed, it is shown in [1] that the particular solution for a thin toroidal shell agrees with the membrane solution. In the general case, the tensile forces in a shell not closed in two coordinates are determined by membrane theory; the membrane state of stress is determined

taking the solution obtained into account. The method of characteristics, used in [2] to analyze membrane shells, is used to solve the problem. The fundamental differential equation is solved by means of a special integral transform using Fourier series. Results of a numerical computation on an electronic computer and of an experiment are presented.

A thin elastic toroidal shell bounded by the coordinates $0 \leq \varphi \leq \pi$ and $-\pi/6 \leq \theta \leq \pi/6$ is considered. An external edge moment M_y is applied to the edge $\theta = -\pi/6$ through a stiff disc which is rotated through an angle ω_y around the y -axis. The outer edge $\theta = \pi/6$ is clamped rigidly and remains fixed. The edges $\varphi = 0$ and $\varphi = \pi$ are free of external forces (see Fig. 1).

The fundamental differential equation of a toroidal shell under a bending load is [1]

$$(\lambda + \sin \theta) \frac{d^2 Y}{d\theta^2} - 3 \frac{dY}{d\theta} \cos \theta - i2\gamma^2 Y \sin \theta = 4\gamma^4 \Phi(\theta) (\lambda + \sin \theta)^3 \quad (1)$$

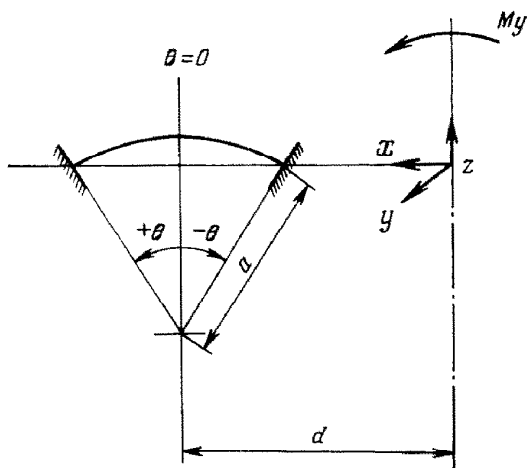

Fig. 1

For thin shells with the ratio $h/R_1 \leq 1/400$, the membrane forces are determined mainly by a particular solution of (1) [3], which agrees with the membrane solution obtained by dividing the right side in (1) by the coefficient of Y [1]. Hence, to determine the tensile forces in a thin toroidal shell which is not closed in two coordinates, membrane theory can be used. The possibility of such a formulation of the problem with boundary conditions given in terms of forces has been noted in [4].

The main equation of a membrane toroidal shell with an edge loading is [5]

$$\frac{1}{R_1 R_2 \sin \theta} \frac{\partial}{\partial \theta} \left[\frac{R_2^2 \sin \theta}{R_1} \frac{\partial U}{\partial \theta} \right] + \frac{1}{R_1 \sin^2 \theta} \frac{\partial^2 U}{\partial \varphi^2} = 0 \quad (2)$$

$$U = -T_2 R_1 \sin \theta$$

For a toroidal shell $R_1 = a$, $R_2 = a/\sin \theta$. After differentiation, (2) becomes

$$\frac{\partial^2 T_2}{\partial \theta^2} (\lambda + \sin \theta) \sin \theta + \frac{\partial T_2}{\partial \theta} (3\lambda + 5 \sin \theta) \cos \theta + T_2 [4 \cos^2 \theta - 2(\lambda + \sin \theta) \sin \theta] + \frac{\partial^2 T_2}{\partial \varphi^2} = 0 \quad (3)$$

Solving the equation of characteristics of the fundamental equation (3) for φ , we find the ordinate for the intersection between the characteristic passing through the origin and the line $\theta = \pi/6$

$$\varphi_0 = \int_0^{-\pi/6} \frac{d\theta}{\sqrt{-(\lambda + \sin \theta) \sin \theta}}$$

In particular, we obtain $\varphi_0 \approx \pi/4$ for $\lambda = 3.44$.

Giving the value of the desired function T_2 on coordinate segments of the intersection

between the characteristic and the line $\theta = -\pi/6$, we obtain the solution of the fundamental equation (3).

The proof of the existence and uniqueness conditions for the solution is given in this case by the Cauchy-Riemann theorem.

The domain in which the problem can be solved is determined from the existence condition for the solution. For $\varphi < \varphi_0$ the influence of the free edge $\varphi = 0$ must be taken into account, outside a domain bounded by the coordinate $\varphi = \varphi_0$ the influence of the edge $\varphi = 0$ is negligible, and the analysis of the shell for $\varphi > \varphi_0$ does not differ from the solution of the analogous problem for a shell closed in the circumferential coordinate.

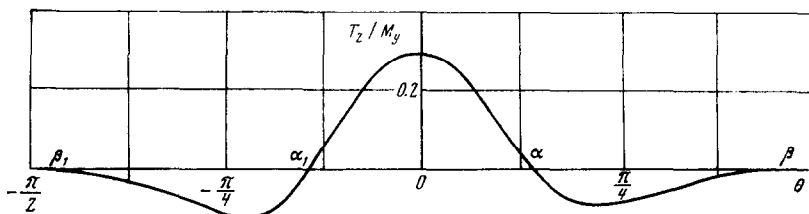

Fig. 2

A diagram of the circumferential forces T_2 in a torus segment closed along φ is given in Fig. 2 for a loading by a moment M_y in the section $\varphi = \varphi_0$. For a section of the shell bounded by the coordinates $\alpha_1 \leq \theta \leq \beta_1$ the boundary conditions are formulated as follows:

$$T_2|_{\varphi=0} = 0, \quad T_2|_{\varphi=\varphi_0} = f(\theta) \tag{4}$$

$$T_2|_{\theta=\alpha_1} = 0, \quad T_2|_{\theta=\beta_1} = 0 \tag{5}$$

where $f(\theta)$ is a given function, the magnitude of the forces T_2 in a shell closed along φ

The solution of the fundamental equation (3) is determined by the Fourier series [6]

$$T_2 = \sum_{s=1}^{\infty} T_s \sin \frac{\pi s \varphi}{\varphi_0}, \quad T_s = \frac{2}{\varphi_0} \int_0^{\varphi_0} T_2 \sin \frac{\pi s \varphi}{\varphi_0} d\varphi \tag{6}$$

where the function T_s is determined from the solution of the ordinary differential equation obtained from (3) by a transformation which is defined by the second expression in (6).

The series obtained do not satisfy the second boundary condition in (4) on the edge

$\varphi = \varphi_0$. To obtain the final solution, it is necessary to augment the series (6) by an appropriate series (in the functions $\sin \pi s \varphi / \varphi_0$) for an auxiliary function F which takes the same values on the boundaries of the interval $\varphi = 0$ and $\varphi = \varphi_0$ as does the desired function T_2 .

The diagram of T_2 in the section $\theta = -0.4$, the result of an electronic computer computation by the method presented, is produced in Fig. 3 (curve 1).

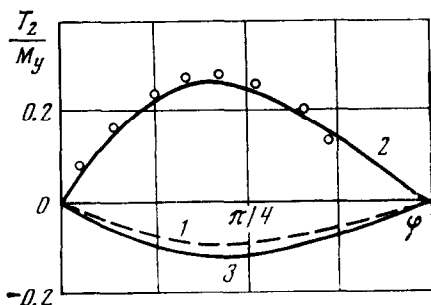

Fig. 3

The following approximate methods can be used for a qualitative estimate. For $\theta = 0$ the fundamental equation (3) degenerates into the parabolic equation

$$\frac{\partial^2 T_2}{\partial \varphi^2} + 4T_2 + 3\lambda \frac{\partial T_2}{\partial \theta} = 0 \tag{7}$$

Separating variables and integrating the equation with respect to θ , we obtain

$$\int \frac{dz}{z} = - \frac{R^2}{3\lambda} \int d\theta, \quad \ln |z| = - \frac{R^2}{3\lambda} \theta \tag{8}$$

For $\theta = 0, z = 1$ the solution of (7) becomes

$$T_2 = C_1 \sin \delta \varphi + C_2 \cos \delta \varphi, \quad \delta = \sqrt{4 - R^2}$$

(R is a constant obtained in the separation of variables).

We take the boundary conditions (4) for (7). Taking account of the first condition in (4), we obtain

$$T_2 = C_1 \sin \delta \varphi$$

We have for the functions T_2^* and $dT_2^*/d\varphi$

$$T_2^* |_{\varphi=\varphi_0} = T_{2(1)}^* \cos \varphi_0, \quad \left. \frac{dT_2^*}{d\varphi} \right|_{\varphi=\varphi_0} = - T_2^* \sin \varphi_0 \tag{10}$$

for a periodic state of stress in a shell closed along φ under a loading by the edge moment M_y in the section $\varphi = \varphi_0$, where $T_{2(1)}$ is the magnitude of T_2 in the section $\varphi = 0$ in a torus segment closed along φ . Taking account of (9), we have in the sector of a torus segment

$$T_2 |_{\varphi=\varphi_0} = C_1 \sin \delta \varphi_0, \quad \left. \frac{dT_2}{d\varphi} \right|_{\varphi=\varphi_0} = C_1 \delta \sin \left(\delta \varphi_0 + \frac{\pi}{2} \right) \tag{11}$$

Equating the desired function T_2 and its derivative to analogous known values for a shell closed along φ , we obtain a transcendental equation from (10) and (11) to determine δ

$$- \operatorname{tg} \varphi_0 \sin \delta \varphi_0 = \delta \sin (\delta \varphi_0 + \pi/2)$$

In the case under consideration $\delta = 2.4$ from this equation. A graph of function T_2 at the section $\theta = 0$ is presented in Fig. 3 (curve 2). Shown in this graph are the data from an experiment performed on shells of thickness $h = 0.01$ cm with geometric parameters $a = 3.2$ cm, $d = 11$ cm fabricated from 12X18H10T brand steel.

Taking $\sin \theta \approx \theta$ and $\cos \theta \approx 1$ in (3) as the angle θ varies between $-\pi/6 \leq \theta \leq \pi/6$, we obtain

$$\frac{\partial^2 T_2}{\partial \theta^2} (\lambda + \theta) \theta + \frac{\partial T_2}{\partial \theta} (3\lambda + 5\theta) + T_2 [4 - 2(\lambda + \theta) \theta] + \frac{\partial^2 T_2}{\partial \varphi^2} = 0 \tag{12}$$

With a 6% deviation of the coefficients of the equation from the exact value, we take $3\lambda + 3\theta$ for the coefficient of the first derivative in (12) and the quantity $\lambda + \theta = (\lambda + \theta)_*$ (the mean in the interval under consideration). Separating variables in (12), we obtain two equations

$$\theta \frac{d^2 X}{d\theta^2} + a \frac{dX}{d\theta} + X (b + c\theta) = 0, \quad \frac{d^2 Y}{d\varphi^2} + R^2 Y = 0$$

$$a = 3, \quad c = -2, \quad b = (4 - R^2)/(\lambda + \theta)_*$$

Introducing the new function $X = \theta^{-a/2} U(\theta)$ in the first of these equations and making the substitution $\xi = \theta \sqrt{-4c}$, we obtain the Whittaker equation

$$4\xi^2 \frac{d^2 U}{d\xi^2} = (\xi^2 - 4n\xi + 4m^2 - 1) U$$

$$n = \frac{b}{\sqrt{-4c}}, \quad 4m^2 - 1 = 2a + a^2$$

Taking account of the first boundary condition in (4), the general solution of (12) is

$$T_2 = \theta^{-a/2} [C_1 M_{n,m}(\xi) + C_2 W_{n,m}(\xi)] \sin B\varphi$$

$$M_{n,m}(\xi) = e^{-\xi/2} \xi^{m+1/2} \Phi(m-n+1/2, 2m+1, \xi)$$

$$W_{n,m}(\xi) = e^{-\xi/2} \xi^{m+1/2} \Psi(m-n+1/2, 2m+1, \xi)$$

(Φ, Ψ are degenerate hypergeometric functions). The diagram of T_2 in the section $\theta = -0.4$, obtained by this method, is presented in Fig. 3 (curve 3).

The bending state of stress in the sector of a thin toroidal shell segment corresponds to the character of the change in the membrane forces and is determined on the foundation of the membrane solution obtained. Knowing the general character of the change in the state of stress and the magnitude of the moments in the section $\varphi = \varphi_0$ (from the solution of the known problem for a shell closed along the circumferential coordinate), the magnitude of the bending moments can be determined in the section $0 \leq \varphi \leq \varphi_0$.

REFERENCES

1. Chernina, V. S., Statics of Thin-walled Shells of Revolution. "Nauka", Moscow, 1968.
2. Sokolovskii, V. V., Membrane equations of equilibrium of shells. PMM Vol. 7, № 1, 1943.
3. Stepanov, R. D. and Bogomol'nyi, V. M., On the problem of the bending of a toroidal shell segment. In: Strength Analyses, № 16, Mashinostroenie, Moscow, 1975.
4. Rabotnov, Iu. N., Some solutions of the membrane theory of shells. PMM Vol. 10, № 5, 1946.
5. Novozhilov, V. V., Theory of Thin Shells. Sudpromgiz, Leningrad, 1951.
6. Grinberg, G. A., New method of solving some boundary value problems for the equations of mathematical physics which admit of separation of variables. Izv. Akad. Nauk SSSR, Ser. Fizich., Vol. 10, № 2, 1946.

Translated by M. D. F.

UDC 539.3

BOUNDARY VALUE PROBLEMS FOR AN ELASTIC ANISOTROPIC HALF-PLANE WEAKENED BY A CIRCULAR HOLE

PMM Vol. 40, № 4, 1976, pp. 759-763
Iu. A. AMENZADE and M. B. AKHUNDOV
(Baku)

(Received December 8, 1975)

A method is given for solving some boundary value problems for a half-plane with a circular hole. It is assumed that the material of the half-plane possesses rectilinear anisotropy of a general kind and that planes of symmetry perpendicular to the O -axis exist. The half-plane is weakened by a circular hole L_1 of unit radius subjected to an internal pressure p . The affix of the center of L_1 (Fig. 1) is denoted by \ddot{u}